

BVI-24B-TO

Appliance Designation	Beverage Storage
GTIN	5061068710510
EEl Class	B
Rated EEl	134
Noise Level dB(A)	36dB
Noise Class	B
Rated annual energy consumption	175 kWh/annum
Climate Class	T - 18-43°C
Compressor	Inverter compressor
Refrigerant	R600A
Fan Assisted Cooling	Yes
Ventilation Required	Plinth ventilation and service channel
Temperature Range	2 to 14
Zone Type	1 zone
Defrosting Type	Manual
Installation	In column / integrated
Door	Black glass
Door Handle	Push2open
Door Open Direction	RH hinged
Reversible Door	Yes
Door-Open Alarm Function	Yes
Lock	No
Capacity (L)	62L
Standard Storage Quantity	45 X 330 mL cans + 6 X 750mL wine
Shelves	1 glass shelf + base shelf
Shelf Type	Telescopic rail
Light	LED - 3000-6000k (dimnable) + RGB
Auto. Lighting Function	Yes
Control	TFT touch display - full colour
Control Display Colour	Full colour
Charcoal Filter	Yes
Softclose	Yes
Heating Ability	No
Internal Humidity	55-85% - automatic
Vibration Free	Yes
Power Lead Length	1.5m
Adjustable Feet	Yes - 15mm
Warranty	3 years P & L

Body Dimension / Weight

H595 x W595 x D575mm

47kg

Packing Dimension / Weight

H680 x W700 x D700mm

52kg



ENERGY LABEL



175 kWh/annum

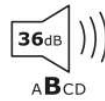
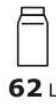

2019/2016

BOTTLE LOADING

BOTTLE LOADING DIAGRAM

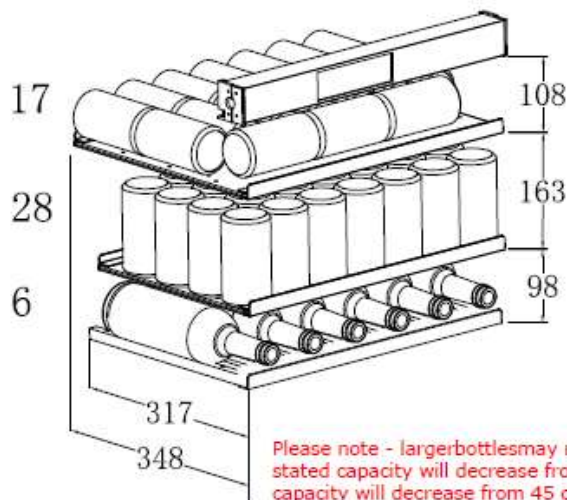
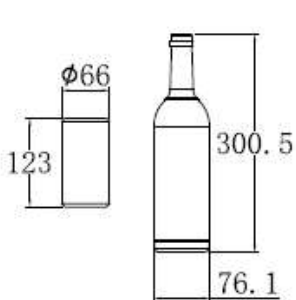
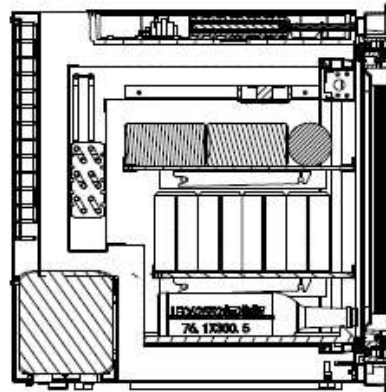
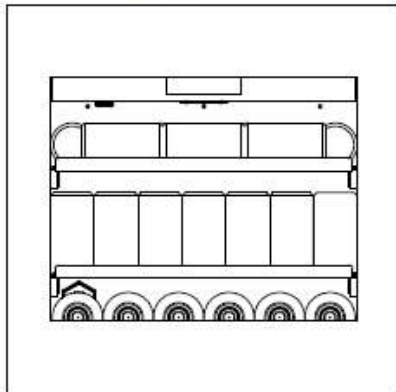

Please note - larger bottles may require a shelf removing and the stated capacity will decrease from 6 Bordeaux bottles, the stated capacity will decrease from 45 cans.

INSTALLATION

