

# CELLA

## WBV75D-BLACK

Appliance Designation	Wine Storage
GTIN	5061068710329
EEL Class	F
Rated EEL	123.4
Noise Level dB(A)	40
Noise Class	C
Rated annual energy consumption	154 Kwh/annum
Climate Class	T
Compressor	Jiaxipera inverter compressor
Refrigerant	R600a
Fan Assisted Cooling	Yes
Ventilation Required	Plinth Ventilation
Temperature Range	Both Zones - 1-20°C
Zone Type	Dual Zone
Defrosting Type	Manual
Installation	Freestanding / Built-in
Door	Black - triple glazed door, UV treated and Low-E glass door
Door Handle	Black Handle
Door Open Direction	From left side
Reversible Door	Yes
Door-Open Alarm Function	Yes
Lock	Yes
Capacity (L)	202
Standard Storage Quantity	76 x 330ml cans & 36 Bordeaux bottles
Shelves	Upper: 3pcs glass shelves Lower: 3pcs beech wood shelves, 1 wooden bar at the bottom
Shelf Type	Sliding (not telescopic)
Light	Warm white strip LED lighting - 2800k-3000k
Auto. Lighting Function	Included
Control	LED Display
Control Display Colour	White
Charcoal Filter	Included
Carbon Filter	Yes - replace every 12 months
Heating Ability	Yes
Internal Humidity	50 - 85%
Vibration Free	Yes
Power Lead Length	1.5m
Adjustable Feet	Yes - 70mm
Warranty	3 Years Parts & Labour

### Body Dimension / Weight

W490 x D480 x H1775mm

64kg

### Packing Dimension / Weight

W555 x D572 x H1930mm

76kg



**Minimum ambient temperature for which the refrigerating appliance is suitable is 18 °C**

**Maximum ambient temperature for which the refrigerating appliance is suitable is 43 °C**

## Bottle Loading

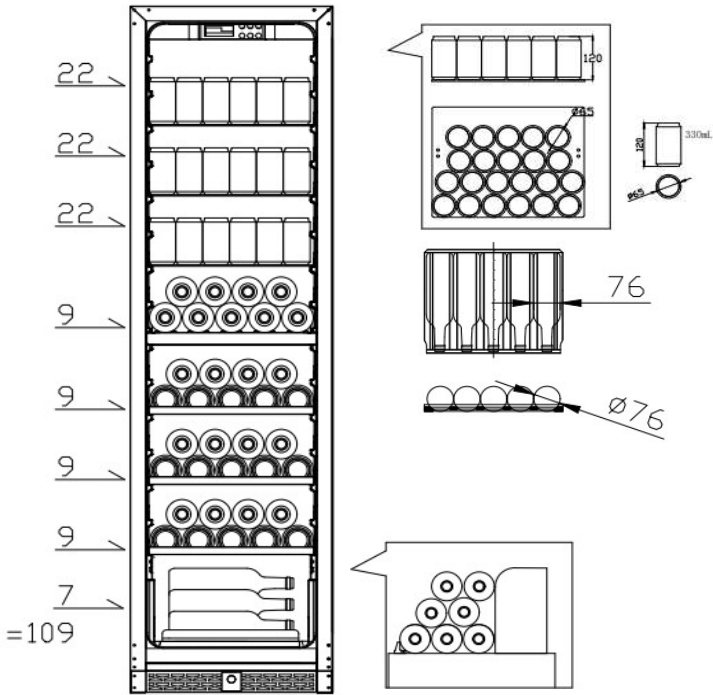

## Energy Label



ELITE WINE REFRIGERATION LTD WBV75D-BLACK



154 kWh/annum



204 L



40dB

ABCD

90020006

## Installation

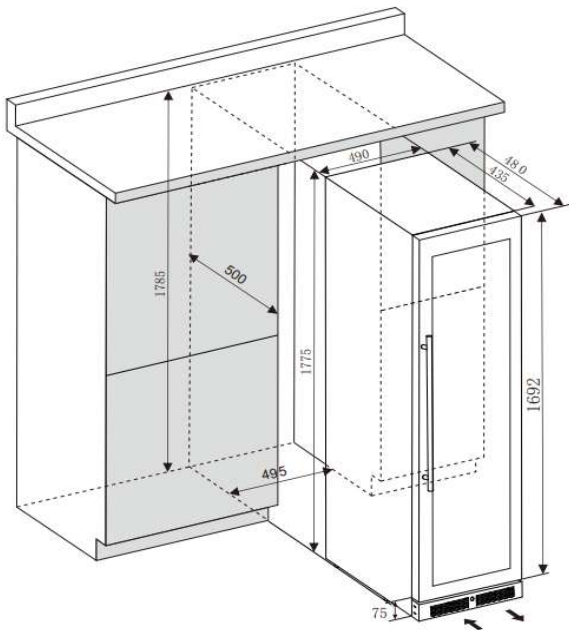

Front View

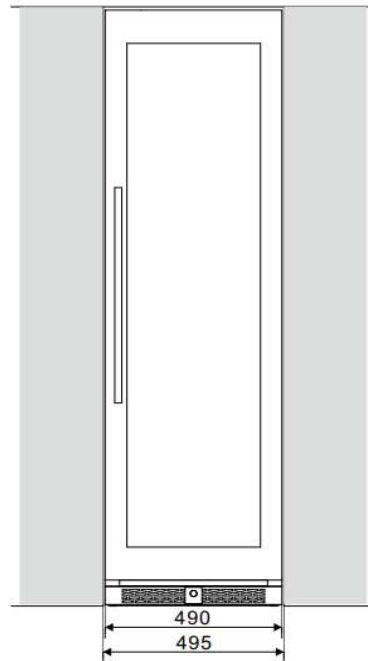

Side View

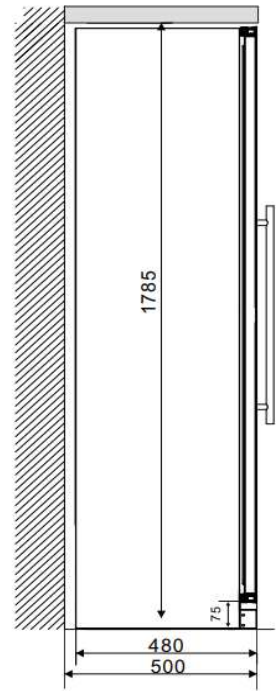

Top View

